

## Studio monitor setup stencil

### Instructions:

Centre of Template: Head/Listening Position

Set Primary Angles: Monitor(L) → Head → Monitor(R) "60° Rule"

Correct Imaging #1: Monitors → Head + Monitor → Monitor Distance

Correct Imaging #2: Use Tilt + Toe-in for Monitor → Ear Directionality

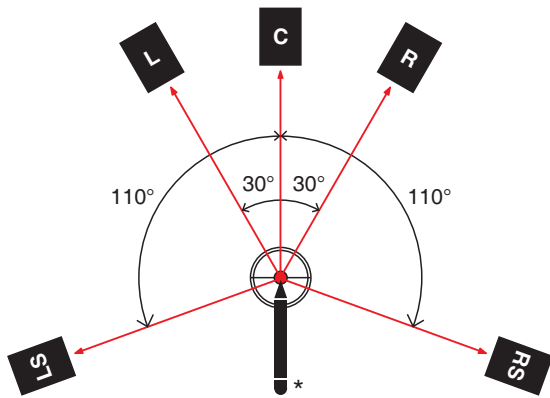

\*Use laser-pen for accurate alignment. Alignment/Angle = Tweeter → Ear

### Positions:

- Listening Position Location-point
- Front Stereo 30~40° From Centre [L|R]
- 5.1 Surround Sound 100~120° [LS|RS]
- 6.1 Surround Sound 135~160° [LS|RS] | 180° [B]
- 7.1 Surround Sound 90~110° [LS|RS] | 130~150° [BLS|BRS]

